

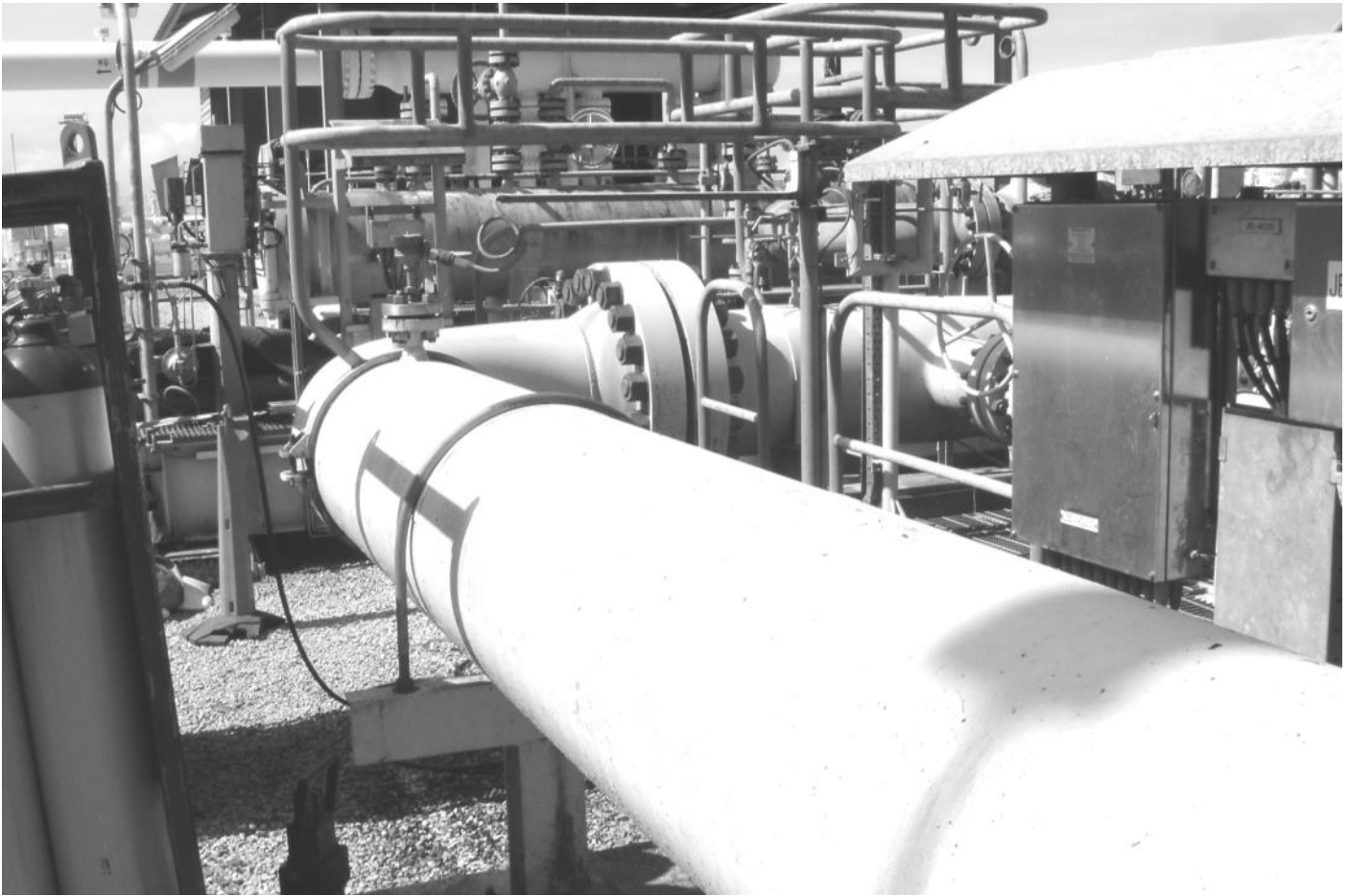

594752 (M)

IDC Training House

LAST UPDATED 19-11-2020



PIPING DESIGN & ARRANGEMENT

COURSE DURATION: 5 DAYS

REACH US Today for Greater Safety, Quality, Reliability, Productivity, Profitability
HRD Approved "Class A" Training Provider (since Year 2002). Registered with Ministry of Finance



COURSE DESCRIPTION

This course aims to transfer useful and essential knowledge related to design and layout of piping system which can help the participant broaden the existing knowledge he holds.

The program gives a **comprehensive knowledge of piping fundamentals** which includes the various piping components, their international standards, materials, drawings involved from start to end of a piping project, drawings terminology and the concept involved in their creation. The program focus on the **real time work related concepts and issues**, which is enhanced by the inputs of the instructor's practical experience.

COURSE OBJECTIVES

Upon the successful completion of the course, participants will be able to:

- ✓ Perform various tasks in his piping works, which can be related to Layout & Design, installation, in a Design Office, EPC Companies, & Plant Owner Companies.
- ✓ Create & Understand Piping Layouts and Isometrics.
- ✓ Create MTO (Material Take off)
- ✓ Establish Pressure Ratings for Piping Components, Valves / Flanges.
- ✓ Understand & Use ASME B 16 Component Standards.
- ✓ Interpret Pipe Properties
- ✓ Understand Equipment Vendor Drawings.
- ✓ Create Equipment Layouts
- ✓ Understand PFD's & P& ID's
- ✓ Select Flange, Gaskets, Valves etc.

COURSE OUTLINE

The course instructor(s) may modify this program before or during the course for technical reasons with no prior notice to participants. Nevertheless, the course objectives will always be met:

MODULE 1) PIPING FUNDAMENTALS

- Process Plants
- Pipe & Tube
- Piping Scope in Projects
- Piping & Pipelines
- Codes & Standards



WHO SHOULD ATTEND?

- Those involved in Piping Engineering field related to Design, Analysis and Operation in
 - * Oil and Gas Refineries
 - * Petrochemical / Chemical / Process / Power / Pharmaceutical / Food Plants
- Engineers dealing with Piping Design, Piping Layout, Piping Site, Piping QA/QC, Piping Stress
- Project Managers, Piping Supervisors, Piping Draftsmen
- Piping Fabricators, Piping Contractors, Piping Material Suppliers
- Process Engineers at all levels who wish to streamline or enhance their existing knowledge
- Anyone of other fields who aspire to make a career in piping

MODULE 2) PIPE DATA

- NPS / IPS
- Wall Thickness
- Pipe Joints
- Pipe Manufacturing
- Pipe Symbols

Exercise: Interpreting Pipe Data

MODULE 3) PIPE FITTINGS

- Elbows
- Branch Connections
- Reducers
- Couplings
- Cap
- Plug
- Union
- Swage
- Stub Ends
- Fitting Ratings
- Drafting Symbols

Exercise: Fittings Representation on drawings

MODULE 4) FLANGES

Types/Ratings/Faces/Bolts & Nuts/Gaskets

- Slip on
- Weld Neck
- Socket Weld
- Screwed
- Loose/Lap Joints
- Reducing
- Blind

Exercise: Flange Type, Facing, P-T rating, Material Selection.

MODULE 5) VALVES

Valve Parts/Trim/Ratings/Data Sheets

- Gate
- Globe
- Angle
- Check
- Needle
- Diaphragm
- Butterfly
- Special Purpose Valves
 - * Flush Bottom Valves
 - * Foot Valves
 - * Float Valves
 - * Three/Four Way Valves
- Piston
- Knife Gate
- Safety/Relief Valves
- Control Valves
- Ball
- Plug

Exercise: Valve Type, Material, Pressure Class selection



COURSE DURATION

- 5 Days Training

DAILY SCHEDULE

- 8:30am - 5:30pm

ITEMS TO BRING

- Calculator
- Lots of Questions
- A "CAN-DO" Attitude

Stationeries such as pen and highlighter will be provided.

MODULE 6) PIPE MATERIALS

- Metallic Pipe Materials
- Non Metallic Pipe Materials
- ASTM Pipe/component Specifications

MODULE 7) PIPING COMPONENT STANDARDS

Scope/Dimensions/Pressure Classes

- ASME B 36.10
- ASME B36.19
- ASME B 16.11
- ASME B 16.9
- ASME B 16.28
- ASME B 16.34
- ASME B 16.10
- ASME B 16.47
- ASME B 18.2.1
- ASME B 18.2.2
- ASME B 16.20
- ASME B 16.21

Exercise: Interpreting Standards to find Dimensions & Pressure Class of Components

MODULE 8) PIPING SPECIAL ELEMENTS

- Strainers
- Rupture Disc
- Steam Trap
- Flame Arrestor
- Vortex Breaker
- Blanks
- Spacers
- Expansion Joints

MODULE 9) MECHANICAL EQUIPMENTS

- Static & Rotary Equipments
- Static Equipments
 - * Horizontal vessels
 - * Distillation Columns
 - * Heat exchangers
 - * Reboilers
 - * Reactors

MODULE 10) FLOW DIAGRAMS

- BFD
- PFD
- PID
- UFD
- Line Numbering on PID
- Equipment Vendor Data/PDS,
- Nozzle Schedule
- Nozzle Orientation

Exercise: Print Reading of P& ID's.

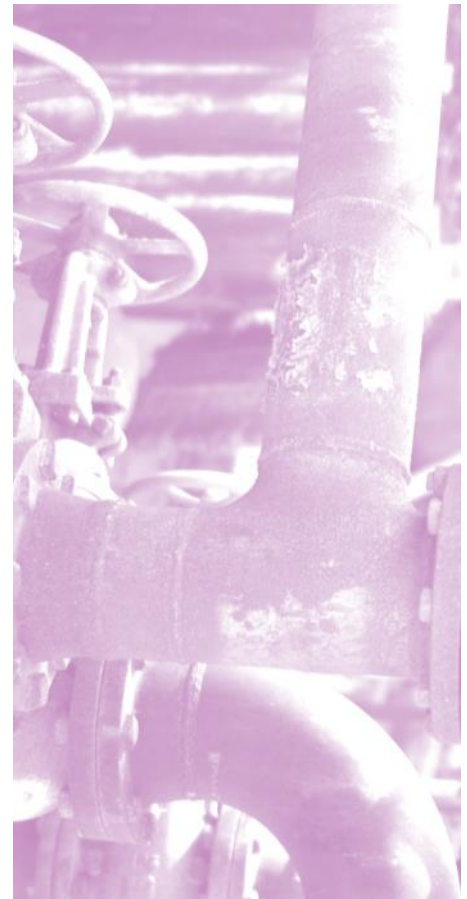

TRAINING METHODOLOGY

This interactive training course includes the following training methodologies as a percentage of total training hours:

- 60% Lectures
- 30% Courses, Group Work & Practical Exercises
- 10% Videos & Software

MODULE 11) INSTRUMENTS

- Flow
- Pressure
- Temperature
- Level
- Hook-up Drawings

Exercise: Identifying the Instrument Location

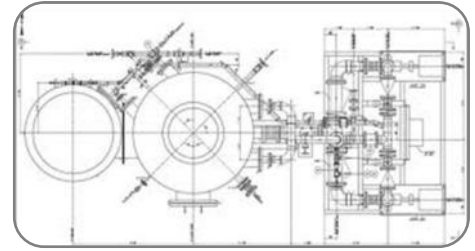

MODULE 12) PLOT PLAN, EQUIPMENT LAYOUT

- Development
- Equipment Layout Types
- Control Point/Bench Mark
- Layout Terminology

Exercise: Locating the Equipment in the Plant Area

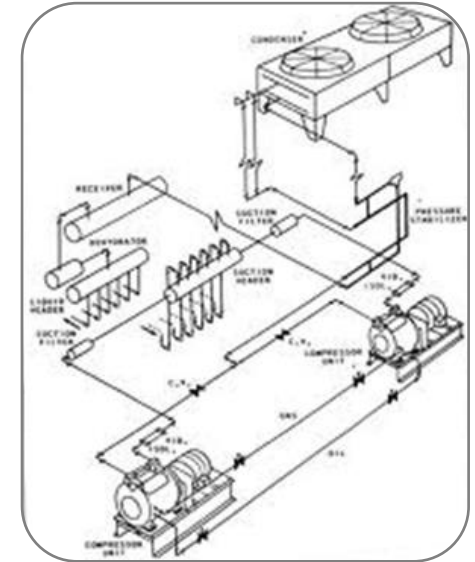

MODULE 13) PIPING LAYOUT

- PMS
- Pipe Routing
- Piping Study Drawings for Equipments (Pipe Rack, Column, Storage Tank, Heat Exchanger, Pump, Compressor etc)

Exercise: Print Reading of GA. & Create Piping Layouts

MODULE 14) PIPING ISOMETRICS

- Drawing Isometrics
- Isometric Dimensions
- Isometric Offset
- Piping Spools

Exercise: Print Reading & Create Piping Isometrics

MODULE 15) PIPE SUPPORTS

- Primary Supports
- Secondary Supports
- Standard Supports
- Special Supports
- Pipe Rack

Exercise: Locating the supports/Identifying the Supports

MODULE 16) MISCELLANEOUS TOPICS

- Line tracing
- Jacket Piping
- MTO (Material Take Off)
- Corrosion and Material Selection
- Pipe color coding



TRAINER'S PROFILE

SHAMS TABRAZ

Shams Tabraz has over 15 years of experience including plant operations & maintenance, process engineering, plant piping & pipeline layout, design, analysis & Construction experience.

He has served in GSWS Kingdom of Saudi Arabia as Plant Piping Engineer responsible for construction, operations & maintenance of Power Piping for a Power Plant having capacity of 1200 MW.

He has also served as a Piping Design Engineer with CADSOFT, Pune, India responsible to develop piping layouts for various oil & gas projects, successively.

Tabraz joined as a Lead Piping Design Engineer with Sconce Solutions India Pvt. Ltd, and major responsibilities include pipe support design, flexibility analysis, piping & equipment layouts, developing 3D models, piping & pipeline systems design reviews for the next 4 years.

Tabraz has successfully trained more than 1000 piping engineers from different nationalities for piping courses organized by IPEBS.

TECHNICAL QUALIFICATIONS

Tabraz holds a Bachelor's in Mechanical Engineering from JNTU, Hyderabad with an additional Post Graduate in Piping Engineering. Currently Tabraz is a Lead Piping Engineer with IPEBS and is responsible for training, consulting, developing course material etc.

- ✓ 2002: Masters in Piping Engineering Maharashtra Institute of Technology, Pune, India.
- ✓ 2000: B. Tech Mechanical in Shadan College of Engineering & Technology, Hyderabad, India.

EXPERTISE IN

- Piping Materials
- Equipment Layouts
- Piping Classes (PMS)
- Piping layouts including Pipe line Routing
- Piping Isometrics
- Nozzle Orientation Diagrams
- Pipe Rack study
- MTOs
- Pipe supports
- Identifying Critical lines
- Making loops for critical lines
- Study of P&ID diagrams
- Study of Technical Piping Specifications
- CAESAR II
- PDMS
- SP3D
- Various International Codes & Standards (ASME B31.1, ASME B31.3, ASME B31.4, ASME 31.8, API etc.)

CLIENTS SERVED

Tabraz has offered several corporate training programs for piping design & engineering for major engineering corporates such as:

- Petrodar Operating Co. Sudan
- Intergraph Consulting India
- PetroVietnam Shipyard, Vietnam
- Aveon Offshore Nigeria

